

**SUBMITTAL  
DATA**



**Schwank superTube Series  
Model SST-M**

**MODULATING LOW INTENSITY GAS-FIRED  
INFRARED TUBE HEATERS**

<b>PROJECT:</b>	
<b>ENGINEER:</b>	
<b>CONTRACTOR:</b>	
<b>DISTRIBUTOR:</b>	
<b>SCHWANK MODEL #:</b>	
<b>FUEL:</b>	N.G. Propane
<b>APPROVED BY:</b>	
<b>DATE:</b>	
<b>APPROVAL #:</b>	



**NOTICE:**

Schwank reserves the right to make changes to equipment and specifications without obligation or notification.

This publication, or parts thereof, may not be reproduced in any form, without prior written consent from Schwank.  
Unauthorized use or distribution of this publication is strictly prohibited.

Schwank  
5285 Bradco Boulevard  
Mississauga, Ontario,  
L4W 2A6

2 Schwank Way  
Waynesboro, Georgia,  
USA 30830

Customer and Technical Services  
Phone: 1-877-446-3727  
Fax: 1-866-361-0523

e-mail: [csr@schwankgroup.com](mailto:csr@schwankgroup.com)

**[www.SchwankUSA.com](http://www.SchwankUSA.com)**  
**[www.Schwank.ca](http://www.Schwank.ca)**

QTY.	MODEL	TOTAL HEATER LENGTH	MAXIMUM INPUT (BTU/HR)	MODULATING RANGE (MBH)	TURBULATOR LENGTH & LOCATION	LINE PRESSURE NG / LP	MANIFOLD PRESSURE NG / LP	FLUE & AIR VENTS	SHIPPING WEIGHT (lbs.)
	<b>SST-MB-25-70</b>	70' 0"	250,000	160 — 250	1X 36" in 6th tube	NG 6.0" LP 12.0"	NG 4.0"-2.3" LP 10.0"-5.0"	5.0"	324 lbs.
	<b>SST-MB-25-60</b>	60' 4"						5.0"	282 lbs.
	<b>SST-MB-20-60</b>	60' 4"	205,000	125 — 205	2X 36" in 5th tube	NG 5.0" LP 11.0"	NG 3.5"-2.0" LP 10.0"-5.0"	5.0"	282 lbs.
	<b>SST-MB-20-50</b>	50' 8"						5.0"	239 lbs.
	<b>SST-MB-15-50</b>	50' 8"	155,000	100 — 155	2X 36" in 4th tube	NG 5.0" LP 11.0"	NG 3.5"-2.0" LP 10.0"-4.5"	4.0"	239 lbs.
	<b>SST-MB-15-40</b>	41' 0"			1X 36" in 3rd tube			4.0"	197 lbs.
	<b>SST-MB-11-40</b>	41' 0"	115,000	72 — 115	2X 36" in 3rd tube	NG 5.0" LP 11.0"	NG 3.5"-1.8" LP 10.0"-4.5"	4.0"	197 lbs.
	<b>SST-MB-11-30</b>	31' 4"			1X 36" in 2nd tube			4.0"	154 lbs.
	<b>SST-MB-08-30</b>	31' 4"	80,000	60 — 80	3X 36" in 2nd tube	NG 5.0" LP 11.0"	NG 3.5"-2.2" LP 10.0"-5.5"	4.0"	154 lbs.
	<b>SST-MB-08-20</b>	21' 8"			1X 36" in 1st tube			4.0"	111 lbs.

For all the heaters above; Gas Inlet is 1/2" NPT & Electrical is 120V-60Hz, 145 VA

# SIDE VIEWS OF SYSTEMS

QTY

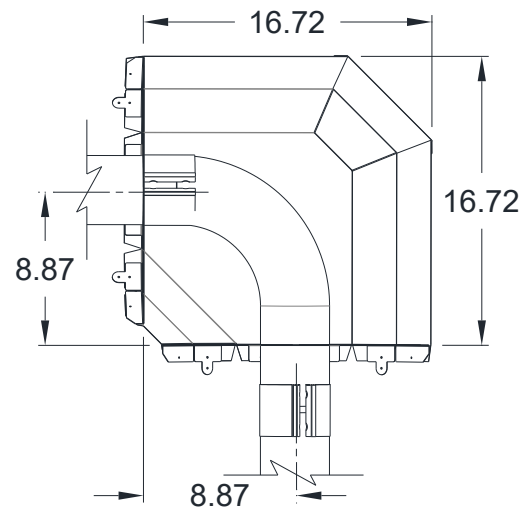
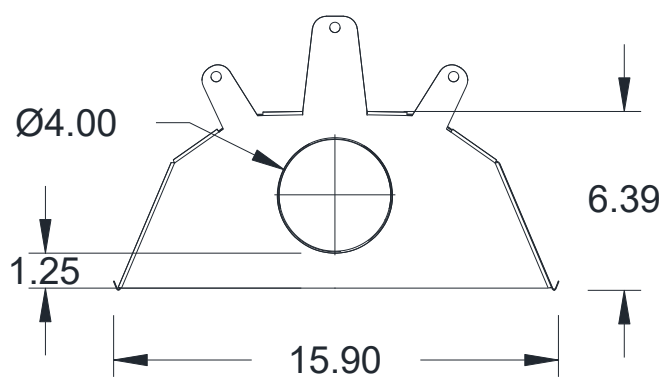
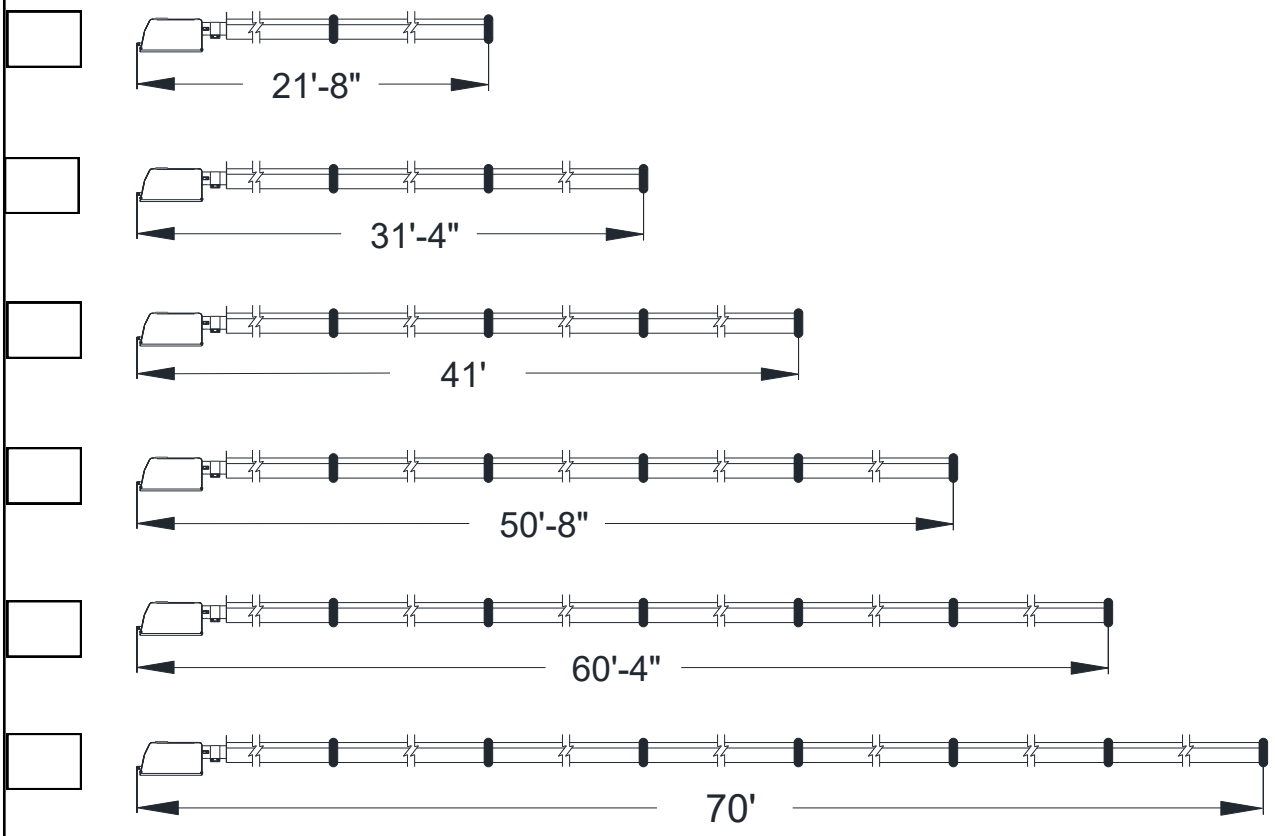

## SST-M STRAIGHT TUBE SYSTEM

<u>COMPONENT QUANTITIES PER HEATER MODEL</u>	<u>SST-M 80-20</u>	<u>SST-M 80-30 115-30</u>	<u>SST-M 115-40 155-40</u>	<u>SST-M 155-50 205-50</u>	<u>SST-M 205-60</u>	<u>SST-M 250-60</u>	<u>SST-M 250-70</u>
10' ALUMINIZED STEEL, SWAGED	1	1	1	1	1	1	1
10' STEEL TUBE, SWAGED, WITH HIGH TEMPERATURE EMISSIVE COATING	1	2	3	4	5	3	4
10' STAINLESS STEEL TUBE, SWAGED	0	0	0	0	0	2	2
FOCUS SHIELD REFLECTOR 10'	2	3	4	5	6	6	7
ALUMINIZED COUPLER	1	2	3	4	5	3	4
ACCUSEAL TUBE CLAMP	0	0	0	0	0	2	2
END PLATE HANGER	1	1	1	1	1	1	1
END PLATE	1	1	1	1	1	1	1

### NOTE: GAS CONNECTOR SIZE

- CANADA: TYPE 1 HOSE GAS CONNECTOR  
 1/2" X 30" 50,000 TO 130,000  
 3/4" X 30" 155,000 TO 250,000
- U.S.A.: STAINLESS STEEL FLEXIBLE GAS CONNECTOR  
 1/2" X 24" 50,000 TO 130,000  
 3/4" X 24" 155,000 TO 250,000

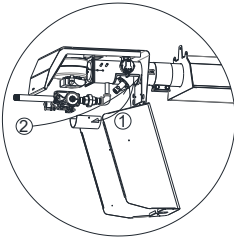

### REMOVING THE BURNER CUP AND THE ORIFICE

- Unscrew the 2 screws holding the burner cup cover and remove the cover
- Break the burner cup loose and unscrew it.
- Move the burner cup forward a little and tilt the stem down.
- Pull out the Burner cup.
- Once the burner cup is removed the orifice can be reached at the orifice holder in the combustion chamber.

<u>OPTIONAL ACCESSORIES</u>	QTY THIS PROJECT
90 DEGREE SWAGED ELBOW KIT JS-0508-SST 1 elbow, 1 coupler, 2 webbed braces, 90 deg. Reflector & hardware	
180 DEGREE SWAGED ELBOW KIT 2 x JS-0508-SST Two 90 degree swaged elbow kits	
FRESH AIR INTAKE WALL HOOD JS-0532-VC	
WALL VENT TERMINAL 102 mm (4") JA-0528-XX	
WALL VENT TERMINAL 152 mm (6") JA-0529-XX	
FLUE VENT TEE 4" x 4" x 6") JA-0514-XX	
COUPLING KIT FOR VENT TEE JA-0516-SW	
TRU-TEMP 24V SET BACK THERMOSTAT JM-0150-XX	
24 VOLT DIGITAL THERMOSTAT JS-0569-WR	
MODULATING THERMOSTAT 24 VOLT JS-0569-MT	
RELAY MULTIPLE HEATERS / 24V THERMOSTAT 2 TO 7 HEATERS PER THERMOSTAT JM-0303-KT	
NOTE: ALL VENT PIPE FIELD SUPPLIED BY OTHERS	
ROOF VENT TERMINALS FIELD SUPPLIED BY OTHERS	

## MINIMUM CLEARANCES TO COMBUSTIBLES

superTube SST Models (BTU/HR)	superTube HEATER SERIES CLEARANCES IN INCHES							
	SUSPENDED HORIZONTALLY				SUSPENDED AT AN ANGLE UP TO 45°			
	Top A	Side S	Bottom C	Side S	Top D	Back B	Bottom C	Front F
80,000	5	24	62	24	5	3	60	54
115,000	5	26	74	26	5	3	70	62
155,000	6	30	80	30	7	4	74	66
205,000	8	40	88	40	10	6	78	74
250,000	12	44	95	44	14	6	78	82

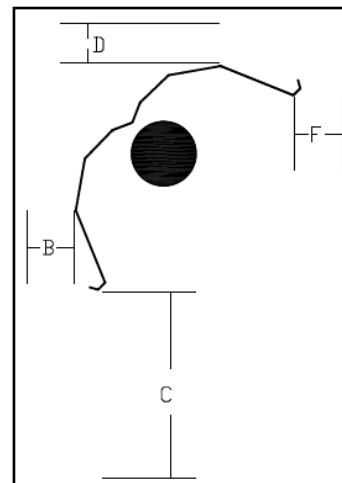
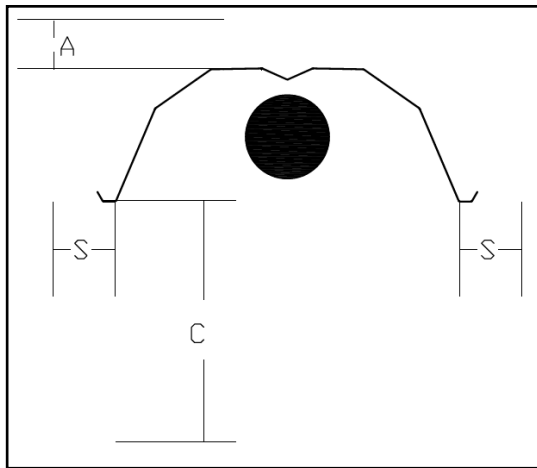

The clearance to combustible material represents the minimum distance that must be maintained between heater and a nearby combustible surface. **The stated clearance to combustibles represents a surface temperature of 90°F (50°C) above room temperature. Some materials such as awnings or plastic may require higher clearances. It is the installer's responsibility to ensure that building materials with a low heat tolerance which may degrade at lower temperature are protected to prevent degradation.**

# TYPICAL HANGER & SUPPORT SPACING RECOMMENDATIONS

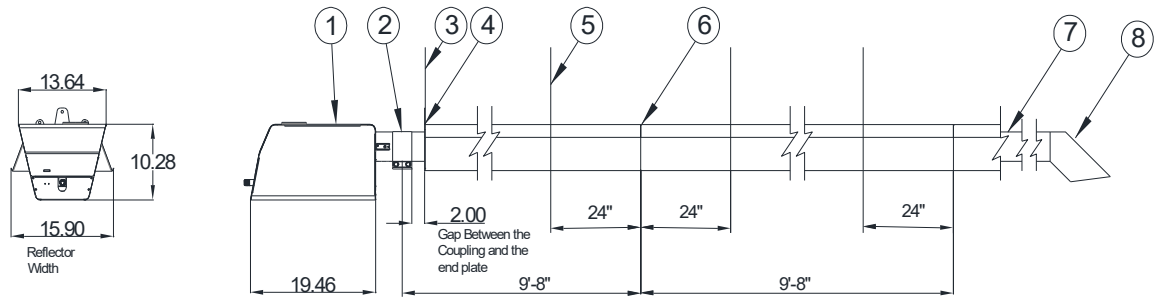

- 1. Burner Assembly
- 2. Coupling
- 3. Suspension Chain or Rod
- 4. Hanger End Plate
- 5. Suspension Chain or Rod
- 6. Section End of Tube Not The Reflector
- 7. 10 ft. Swaged Tube At One End
- 8. Flue Vent Terminal

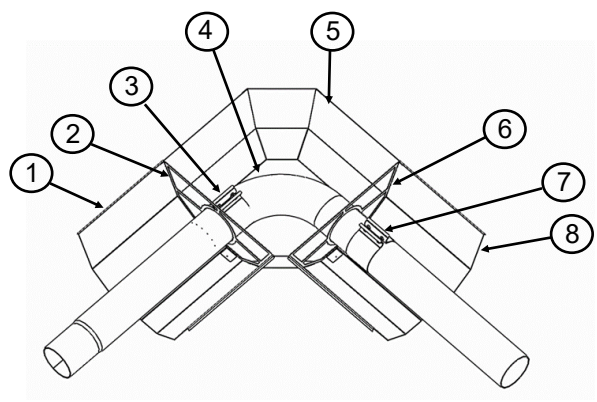

- 1. 10 ft. long reflector
- 2. Webbed brace (flanges facing the 10 long reflector it is attached to)
- 3. Coupling
- 4. 90-degree 4-inch tube elbow
- 5. 90-degree reflector
- 6. Webbed brace (flanges facing the 10 ft. reflector it is attached to)
- 7. Coupling
- 8. 10 ft. long reflector

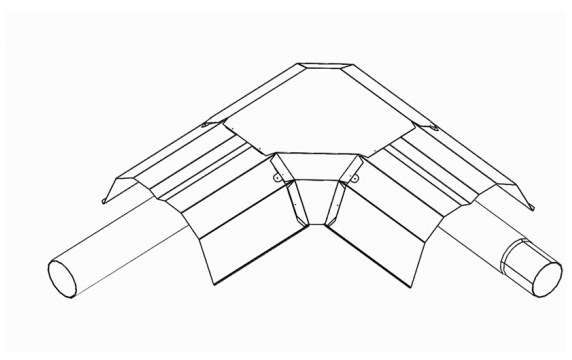

- 1. Install the Webbed Brace on each of the tubes. Be sure to have the flanges facing the ends of the reflectors they are attached to.
- 2. Attach the webbed braces to the ends of the 10 ft. long reflectors, by placing the brace's flanges on top of the reflectors and installing 2 screws in the screw holes.
- 3. Install the 90-degree, 4 inch tube elbow and attach the couplings. Pay attention to the position of the parts with respect to the direction of flow of heat.
- 4. Install the 90-degree reflector over the ends of the two straight reflectors and attach the corner reflector using self drilling screws.

## COMPONENT SPECIFICATIONS

<b>IGNITION</b>	FENWAL DIRECT SPARK MODULE: PRE-PURGE AND POST-PURGE OF TUBE SYSTEM
<b>THERMOSTAT OPTIONS</b> <i>(Factory ready for 24Vac control)</i>	24V MODULATING DIGITAL THERMOSTATNOTE: MULTIPLE HEATERS PER 24V THERMOSTAT REQUIRE RELAY CONTROL CENTER KIT JM-0303-KT
	FIELD SUPPLIED THERMOSTAT BY OTHERS
<b>ELBOWS</b>	90 DEGREE ELBOW 4" DIAMETER, 16 GA. ALUMINIZED STEEL, SWAGED ONE END
	180 DEGREE ELBOW 4" DIAMETER, 16 GA. ALUMINIZED STEEL, 19" ON CENTRE (ASSEMBLY OF TWO 90 DEGREE ELBOW KITS)
<b>HEATER TUBE(S)</b> <b>80 to 205 MBH</b>	COMBUSTION TUBE: 10' x 4" DIAMETER 16 GA. ALUMINIZED STEEL SWAGED ONE END. EACH ADDITIONAL TUBE: 10' x 4" DIAMETER, .16 GA. STEEL TUBES WITH OR WITHOUT HIGH TEMPERATURE EMISSIVE COATING, SWAGED ONE END
<b>HEATER TUBE(S)</b> <b>250 MBH</b>	COMBUSTION TUBE: 10' x 4" DIAMETER, 16 GA. 439 STAINLESS STEEL SWAGED ONE END SECOND TUBE: 10' x 4" DIAMETER, 16 GA. 439 STAINLESS STEEL SWAGED ONE END THIRD TUBE: 10' x 4" DIAMETER, 16 GA. ALUMINIZED STEEL SWAGED ONE END. EACH ADDITIONAL TUBE: 10' x 4" DIAMETER, 16 GA. STEEL WITH OR WITHOUT HIGH TEMPERATURE EMISSIVE COATING SWAGED ONE END
<b>MODULATING CONTROL BOARD</b>	PROPRIETARY MODULATING CONTROL BOARD. MODULATES BLOWER CFM AND GAS VALVE MANIFOLD PRESSURE. FACTORY PREPROGRAMMED FOR NG & LP FUELS. ACCEPTS CONTROL SIGNAL FROM A MODULATING THERMOSTAT OR MODULATION CAN BE CONTROLLED MANUALLY
<b>COMBINATION GAS VALVE</b>	HONEYWELL 24 VOLT NATURAL GAS: 3 1/2" W.C. MANIFOLD UP TO 205,000 MBTUH & FOR 225,000 & 250,000 4.2" MANIFOLD
<b>GAS CONNECTION</b>	USA: FLEXIBLE STAINLESS STEEL GAS CONNECTOR REQUIRED BY CODE: SUPPLIED WITH BURNER CANADA: TYPE 1 GAS HOSE CONNECTOR REQUIRED BY CODE: SUPPLIED WITH BURNER
<b>REFLECTORS</b>	26 GA. ALUMINIZED STEEL REFLECTOR EXTENDS BELOW BOTTOM OF TUBE SURFACE REFLECTORS ARE CLOSED AT START AND END OF EACH STRAIGHT RUN OF TUBES BY MEANS OF END PLATE HANGERS
<b>HANGERS</b>	SYSTEM UTILIZES WIRE HANGERS, TWO PER 10' TUBE. ALLOWING CONVECTION HEAT FLOW ALONG SYSTEM.
<b>COUPLING KIT</b>	ALL ALUMINIZED STEEL COUPLER UP TO 205,000 MBTUH ; STAINLESS STEEL COUPLER FOR FIRST TWO TUBE CONNECTIONS ON 225 & 250 MBTUH
<b>BURNER HOUSING</b>	BOTTOM FOLDS AWAY, PROVIDING ACCESS FROM TWO SIDES, END AND BOTTOM
<b>BURNER</b>	INCORPORATES STEEL BURNER HEAD 24VDC HI EFFICIENCY ECM BLOWER
<b>TRANSFORMER</b>	120/24VAC; 20VA
<b>SAFETY SWITCHE</b>	ONE DIFFERENTIAL PRESSURE SWITCHE SENSES ADEQUATE COMBUSTION AIR AND BLOCKED FLUE
<b>24VDC POWER</b>	120V/24VDC SMPS POWER SUPPLY FOR THE ECM BLOWER
<b>COMBUSTION AIR</b>	COMBUSTION AIR DUCTED DIRECTLY TO 4" COLLAR AT NTAKE OF BLOWER
<b>TERMINAL BLOCK</b>	ALL WIRING CONNECTIONS BY MEANS OF COMMON TERMINAL BLOCK; JUMPER: FOR 120V THERMOSTAT; REMOVE FOR 24V THERMOSTAT
<b>ELECTRICAL CORD</b>	1220 mm (4') LENGTH 16/3 ELECTRICAL SUPPLY CORD WITH 3 PIN GROUNDED PLUG
<b>VENT PIPE</b>	ALL VENT PIPE IS FIELD SUPPLIED BY OTHERS; SINGLE WALL VENT PIPE OTHER THAN PORTION THROUGH WALL OR ROOF MAY BE DOUBLE WALL VENT PIPE
<b>ROOF VENT CAPS</b>	FIELD SUPPLIED BY OTHERS TO MATE WITH VENT PIPE