



## North America's highest-efficiency tube heating solution

The **ultraSchwank** is the most efficient tube [low intensity] heater for industrial and commercial applications with up to 68.4% radiant efficiency\*, for up to 50% fuel savings.

The first tube heater designed with an insulated reflector system. Captures convection heat and increases tube and inner reflector surface temperatures for superior heat retention and greater comfort at lower air temperature.

**Experience Counts:** Schwank is the worldwide market leader and most trusted brand with over 2 million heating appliances sold.

### Features

- Up to 68% radiant efficiency rating\*
- Fuel savings of up to 50%
- Ceramic insulation
- Easy access to "clamshell" burner box
- Smaller gas pipes needed to power the radiant gas tube heater
- Lower commercial heating installation cost

**Optional Accessories** [See back for more details.](#)

- ThermoControl Plus
- TruTemp Thermostat
- Terminal Elbow Kit

**Contact us today for a FREE design and quote!**

\*Independent lab tested: EN 416-2 standard [UHE 200,000 BTU/hr-60 Ft.]



# ultraSchwank - High Efficiency Tube Heater

Information below is intended only as a reference and should not be used when installing equipment. Please ensure you locate the most recent instruction manual for accurate and up to date information.

## Clearances to Combustibles

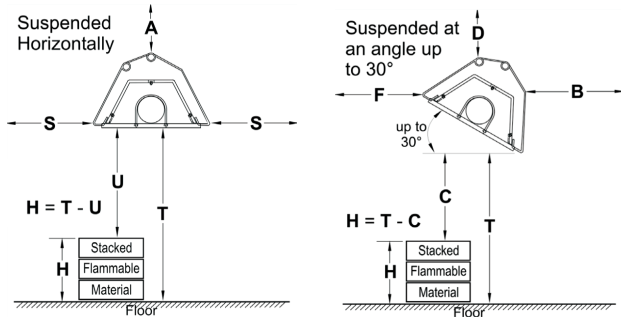

MODEL	SUSPENDED HORIZONTALLY			SUSPENDED AT AN ANGLE UP TO 30°			
	A	S	U	D	B	F	C
UHE 60	0.5"	16"	45"	1.0"	3.25"	35"	41"
UHE 90	1.25"	26"	70"	2.5"	5.25"	50"	60"
UHE 130	1.5"	30"	86"	3.0"	6.25"	57"	70"
UHE 160	3.0"	45"	105"	5.5"	10.0"	75"	85"
UHE 200	3.5"	56"	111"	8.0"	12.5"	90"	93"

\* "T" is a measured distance on site.

## Dimensions and Specifications

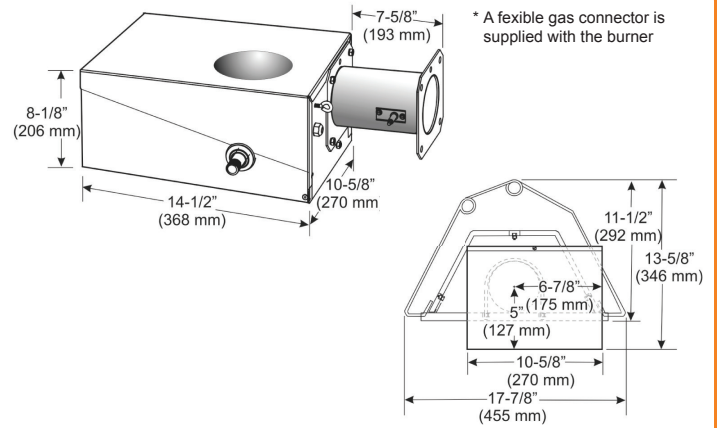

\* A flexible gas connector is supplied with the burner

MODEL	INPUT BTU/HR	SYSTEM LENGTH	WEIGHT LBS.
UHE 60-20	60,000	21'6"	190
UHE 60-30	60,000	31'2"	272
UHE 90-30	90,000	31'2"	272
UHE 90-40	90,000	40'10"	354
UHE 130-40	130,000	40'10"	354
UHE 130-50	130,000	50'6"	436
UHE 160-50	160,000	50'6"	436
UHE 160-60	160,000	60'2"	518
UHE 200-60	200,000	60'2"	518
UHE 200-70	200,000	69'10"	600

## Optional Accessories

Fresh air intake wall cap	JS-0532-VC
4" Horizontal flue vent terminal (wall)	JA-0528-XX
90° Elbow kit with reflector cap (Combine with two 90° to create 180° elbow)	JS-0508-JZ
#2 Lion chain	JL-0800-XX

Consult your local authorized dealer for other Schwank accessories:

- Line-voltage and 24V thermostat and controls
- Side reflector extensions

## Heater Controls & Thermostats

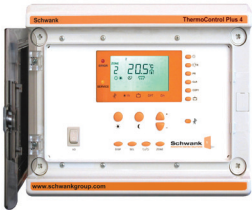

### ThermoControl Plus

#### Intelligent Infrared Heater Control

- Easy to use menu and graphical interface
- Minimal set up and configuration
- Handles up to 8 control zones for single and two-stage applications
- 8 programmable holiday periods per heating zone
- Data acquisition software offers reporting and analysis capabilities



### TruTemp

#### Infrared Setback Thermostat

- Setback reduces control temperature by 9°F [13°C] when a building is unoccupied
- Setback is activated at night time by turning off lights
- Mounts on standard 4" [10cm] electrical box or directly to wall
- Tamper-proof option

Distributor Information:

Gas pressure	Line minimum:	5" W.C. NG
	Line maximum:	14" W.C. NG
	Manifold:	3.5" W.C. NG
Gas inlet	1/2"	
Electrical	120V, 60 Hz, 1.5 AMPS [internal 24V burner components 21VA]	



Installation Manual



Technical Specs



Replacement Parts List

Our customers include:



USA: 2 Schwank Way, Waynesboro, GA 30830 | Canada: 5285 Bradco Blvd. Mississauga, ON L4W 2A6  
Tel: 1-877-446-3727 | Fax: 1-866-361-0523 | www.schwankgroup.com | csr@schwankgroup.com



M021815 RL: v1.5 RD: Mar-2019